

Capacidad (Kg)				Dimensiones (mm)									
P1	P2	P3	P4	A	B	C	D	E	F	G	H	I	J
1.000	700	500	250	1.200	900	1.800	2.000	1.400	1.350	150	860	1.050	680

Modelo	CAT610
Código	754756100
Capacidad de carga	1 T.
Altura de elevación	0 - 1.800 mm
Peso neto	71 kg



METALWORKS

CAT620

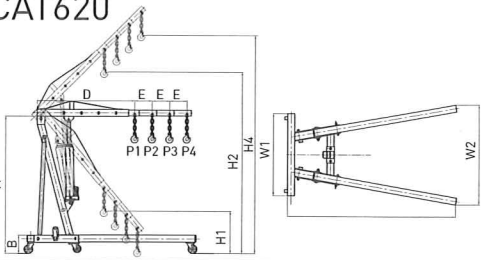

Capacidad (Kg)				Dimensiones (mm)									
P1	P2	P3	P4	A	B	C	D	E	W1	W2	H1	H2	H4
2.000	1.500	1.000	500	1.485	185	1.750	1.015	180	850	1.020	330	1.850	2.300

Modelo	CAT620
Código	754756200
Capacidad de carga	2 T.
Altura de elevación	25 - 2.300 mm
Peso neto	99 kg



METALWORKS

novedad **N** novedad

CAT6200T

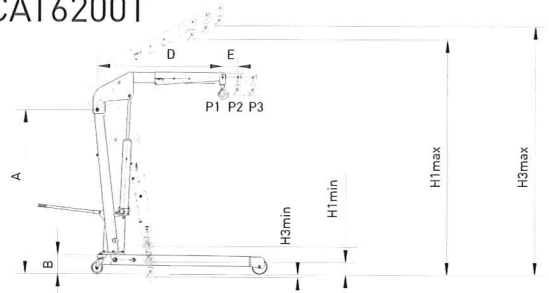

Capacidad (Kg)			Dimensiones (mm)									
P1	P2	P3	A	B	C	D	E	H1min	H3min	H1max	H3max	Anchura total
2.000	1.700	1.500	1.690	205	1.900	1.290	150	230	0	2.505	2.705	1.165

Modelo	CAT6200T
Código	754756220
Capacidad de carga	2 T.
Altura de elevación	200 - 2.650 mm
Peso neto	165 kg



METALWORKS

novedad **N** novedad

De gran resistencia