



MORTAJADORA
SLOTING MACHINE

HE 300

FOLLOW

GIRO DE CABEZAL
TURNING HEADSTOCK



ÚTIL RETIRADA HERRAMIENTA
AUTO TOOL LEFTING DEVICE



EQUIPAMIENTO ESTÁNDAR

- Plato divisor
- Engrasado manual
- Plato de 3 garras universal acoplado
- Juego de bridas de 52 piezas
- Juego de 3 barras
- Dispositivo de retirada de herramienta
- Lámpara de trabajo
- Caja de herramientas
- Certificado CE

STANDARD ACCESORIES

- Dividing head
- Manual lubrication system
- 3 jaw universal chuck mounting
- 52 pieces clamping kit
- 3 slotting bar set
- Auto tool lefting device
- Work light
- Tool box
- CE certificate

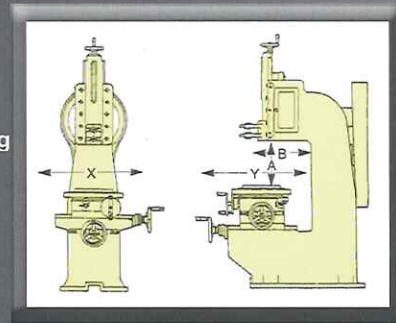

HE300		
Recorrido máximo del carnero (mm)	320	Max. ram travel (mm)
Número de golpes por minuto Hz 50	23 - 42 - 66 - 87	Strokes number per minute Hz 50
Cabezal inclinable a ambos lados	±30°	Tilttable headstock to both sides
Curso vertical regulable del carnero (mm)	0-300	Adjustable vertical travel of ram
Distancia entre final de guía carnero y mesa (A) (mm)	365	Distance between end ram guide and table (A) (mm)
Distancia entre el centro herramienta y columna (B) (mm)	510	Distance between tool centre and column (B) (mm)
Diámetro Plato Divisor (mesa de trabajo) (mm)	560	Dividing head diameter (Work table) (mm)
Recorrido longitudinal mesa de trabajo (X) (mm)	460	Longitudinal travel of work table surface (X) (mm)
Recorrido transversal mesa de trabajo (Y) (mm)	500	Cross travel of work table surface (Y) (mm)
Motor (hp)	3	Motor power (Hp)
Dimensiones (mm) [largo x ancho x alto]	1100X2000X1900	Overall dimensions (mm) [LxWxH]
Peso (Kg)	1500	Weight (Kg)